

Life Fitness Model 8500, 9100, and 9500HR Cross-Trainers

How To... Set Jumpers on CSAFE Card

Tools required: Phillips screwdriver

1. Remove six(6) screws from the FRONT COVER and separate the front cover halves.
2. Set jumpers according to chart below.
3. Reinstall FRONT COVERS.

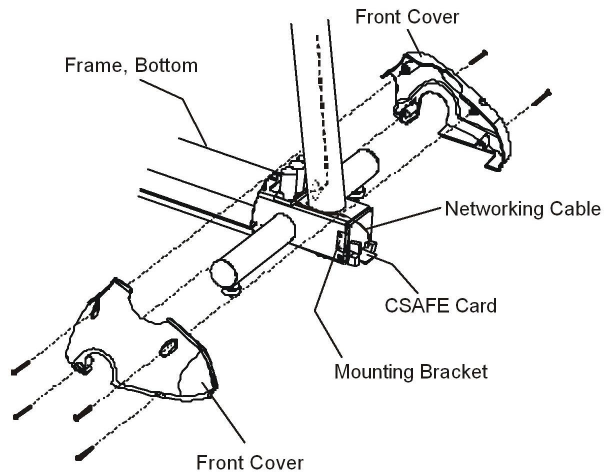

JUMPER SETTINGS					
JW1	JW2	JW3	JW4	JW5	JW6
OUT	IN	OUT	OUT	OUT	IN

